

LX lever hoist

- ▶ Up to 500 kg load capacity
- ▶ Compact and lightweight construction
- ▶ Freewheel function
- ▶ Nickel-plated load chain grade T, series V (G100) in accordance with standard EN 818-7



LX003



LX005

For use in confined spaces

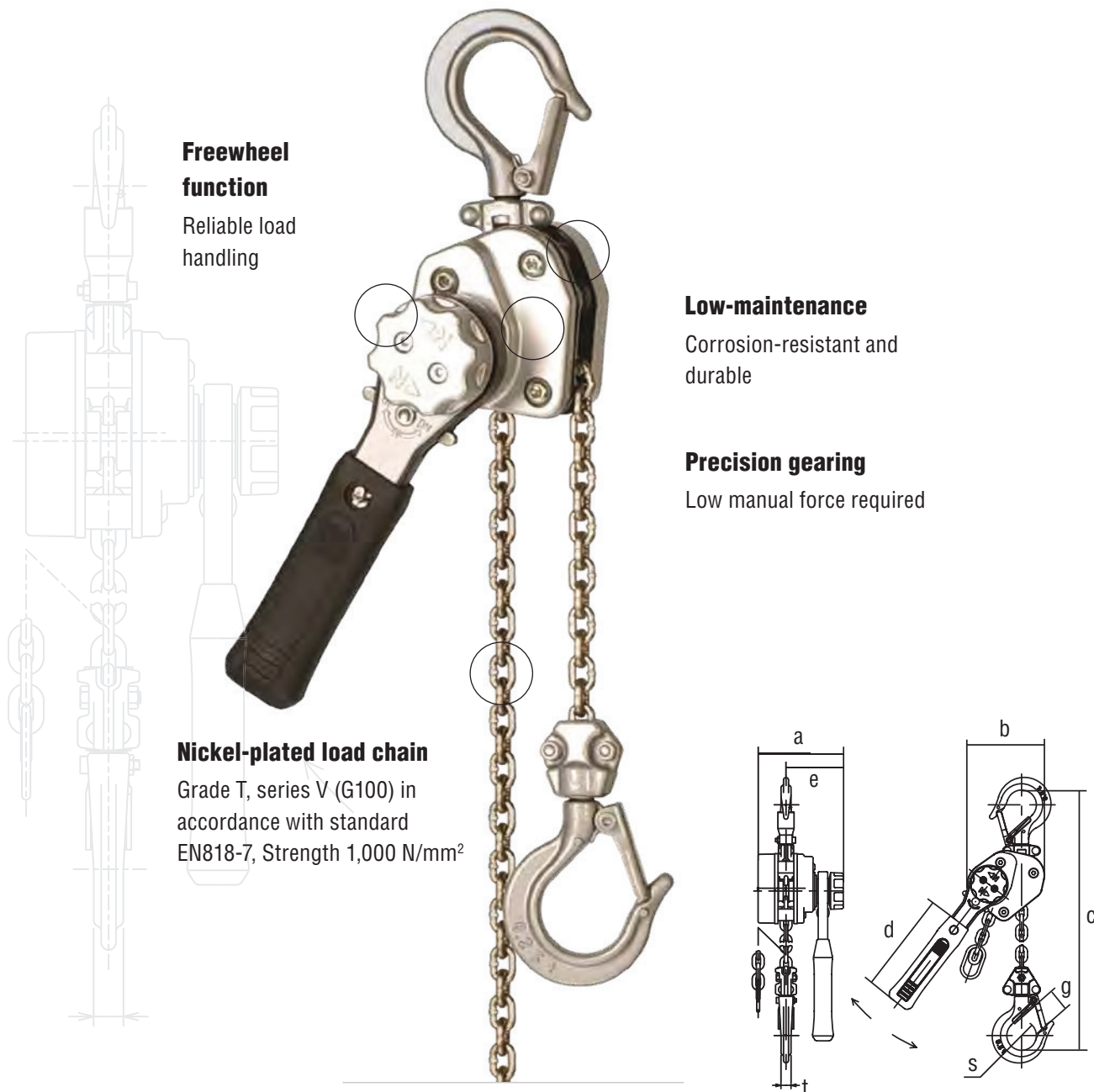

Freewheel function

Reliable load handling

Low-maintenance

Corrosion-resistant and durable

Precision gearing

Low manual force required

Nickel-plated load chain

Grade T, series V (G100) in accordance with standard EN818-7, Strength 1,000 N/mm²

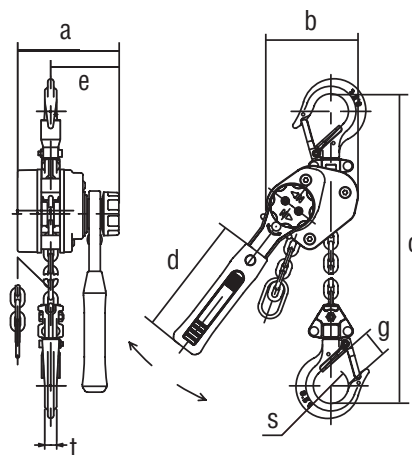

Technical data

Type	Load capacity kg	Standard lifting height m	Lever pressure, full load daN	Load chain diameter mm	Chain falls	Weight kg	Weight for additional 1 m lift kg	Dimensions in mm							
								a	b	c	d	e	g	s	t
LX003	250	1.5 bzw. 3.0	20	3.2 x 9.0	1	1.7 bzw. 2.0	0.2	90.5	73.5	205.0	150.0	62.0	21.0	32.0	11.0
LX005	500	1.5 bzw. 3.0	31	4.3 x 12.0	1	2.7 bzw. 3.3	0.4	102.0	93.0	246.0	180.0	68.0	24.5	35.5	12.0